

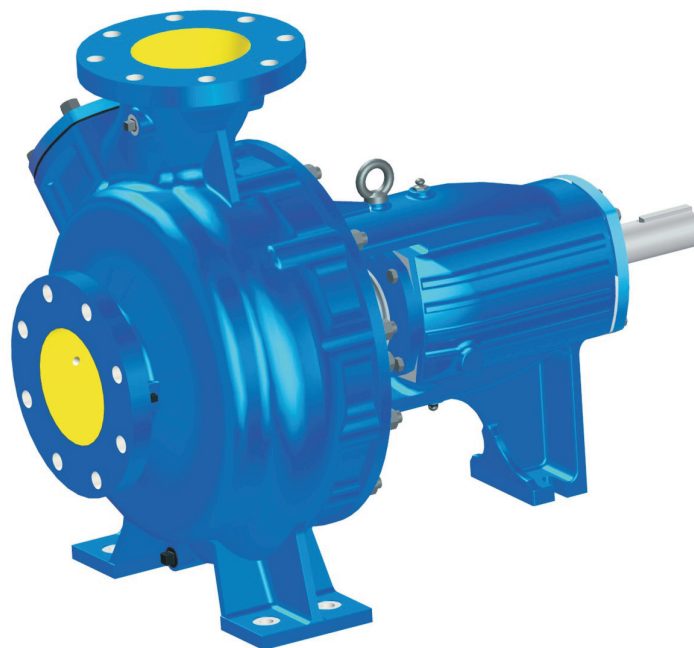

Enriching Lives

SOLIDS HANDLING NON-CLOG PUMPS

TYPE- SHM / SHS / SHV



CE

KIRLOSKAR BROTHERS LIMITED

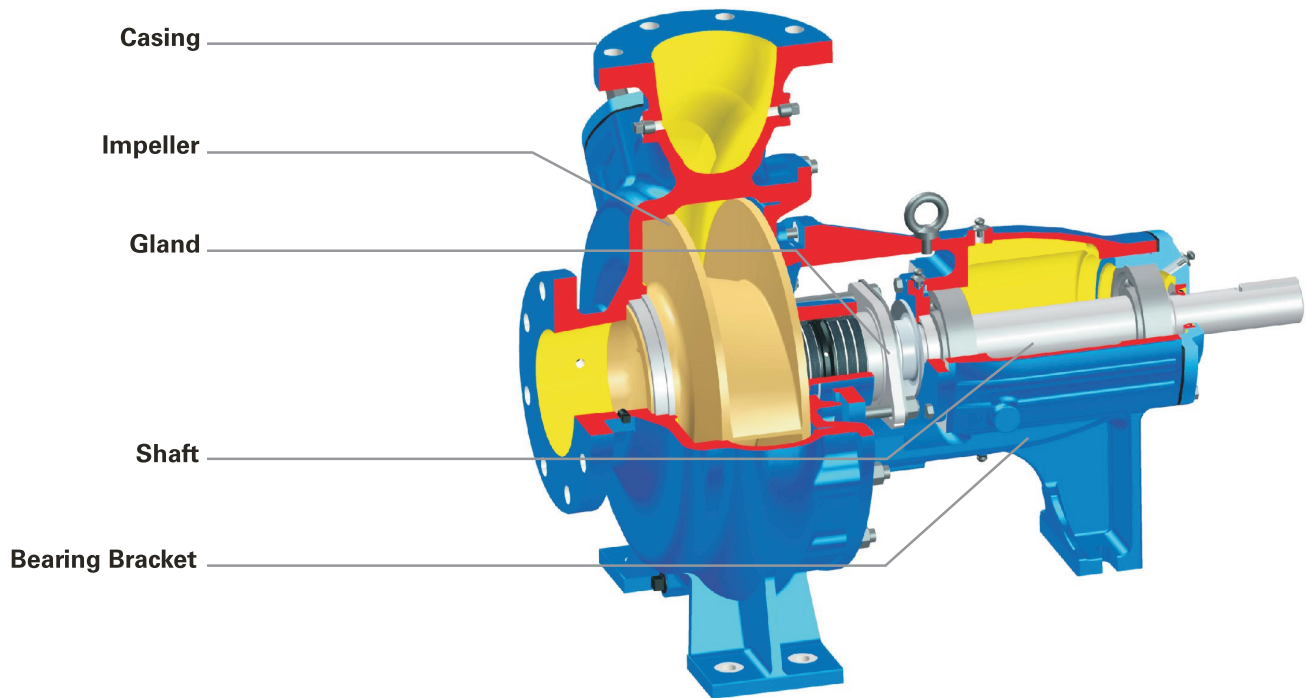

RANGE

Delivery size up to 200 mm

Capacity up to 800 m³/hr

Head up to 90 m

Max. permissible solid size up to 105 mm,
depending on the model consistency up to 5%

QP impellers for more than 6% consistency

Q impellers for more than 4% consistency

APPLICATIONS

For handling liquids with solids in suspension, sludge or pulpy material in Paper Industries, sewage or waste with soft solids in suspension, viscous liquids or liquids carrying fibrous material or powdered material slurries, contaminated process liquids like Sugar factory waste, trade liquors, Water Carrying Gravel, etc.

CONSTRUCTIONAL FEATURES

SHM are horizontal non-clog pumps having single stage, single suction with back pull out type design.

SHS are vertical non-clog pumps for wet pit applications. The pump unit is suspended by a column pipe which also protects the transmission shaft. These pumps can be offered with a column length up to 6.5 m.

SHV are vertical non-clog pumps for dry pit application in vertical orientation to be driven by vertical flange mounted motor which is directly coupled.

Also, SHVT pumps are vertical non-clog pumps for dry pit application in vertical orientation to be driven by vertical flange mounted motor but coupled through transmission shafting.

These pumps operate at 50 Hz.

Pump Casing :

End suction with top centreline delivery as well as horizontal side delivery. High efficiency volute providing smooth unobstructed flow. Delivery flange and feet are cast integral with the casing. A large inspection opening is provided on casing with easily removable cover.

Impeller :

Single suction type non-clog, free flow impeller dynamically balanced. Enclosed or semi-open impellers are available in code N, P, Q or R.

Shafts :

In SHM pumps, four driving units cover the entire range. Shaft is supported by two bearings. Shaft in stuffing box area is protected by a shaft sleeve. Axial clearance between semi-open impeller and suction wear plate can be adjusted externally without dismantling the pump. The shaft sleeves under bearing housing and bearing spider are shrunk fitted to shaft in SHS pumps.

Stuffing Box :

Standard stuffing box is gland packed with grease sealing. Without cooling up to 90°C and with cooling up to 140°C. Mechanical seal option is also available.

Bearings :

SHM Pumps

Standard : Deep groove ball bearings at DE/NDE.

Optional : Deep groove ball bearing at DE and roller bearing at NDE.

A pair of angular contact ball bearings at DE and one cylindrical roller bearing at NDE.

Standard lubrication is grease and optional is oil.

SHS Pumps

Intermediate shaft bearing is rubber (For water Lubrication) and bronze bearing (For grease lubrication).

Thrust ball bearing in combination with metallic journal bearing at head shaft. Transmission bearings are lubricated with external clear water or grease.

Thrust bearings are grease lubricated.

Direction Of Rotation :

Clockwise viewed from driving end.

Drive :

These pumps are suitable for coupling with electric motor or engine directly or through belt drives.

Flanges :

Standard : drilling to DIN 2533 ND 16

Optional : drilling to ASA/BS/IS

GENERAL DIMENSIONS / MOUNTING DETAILS

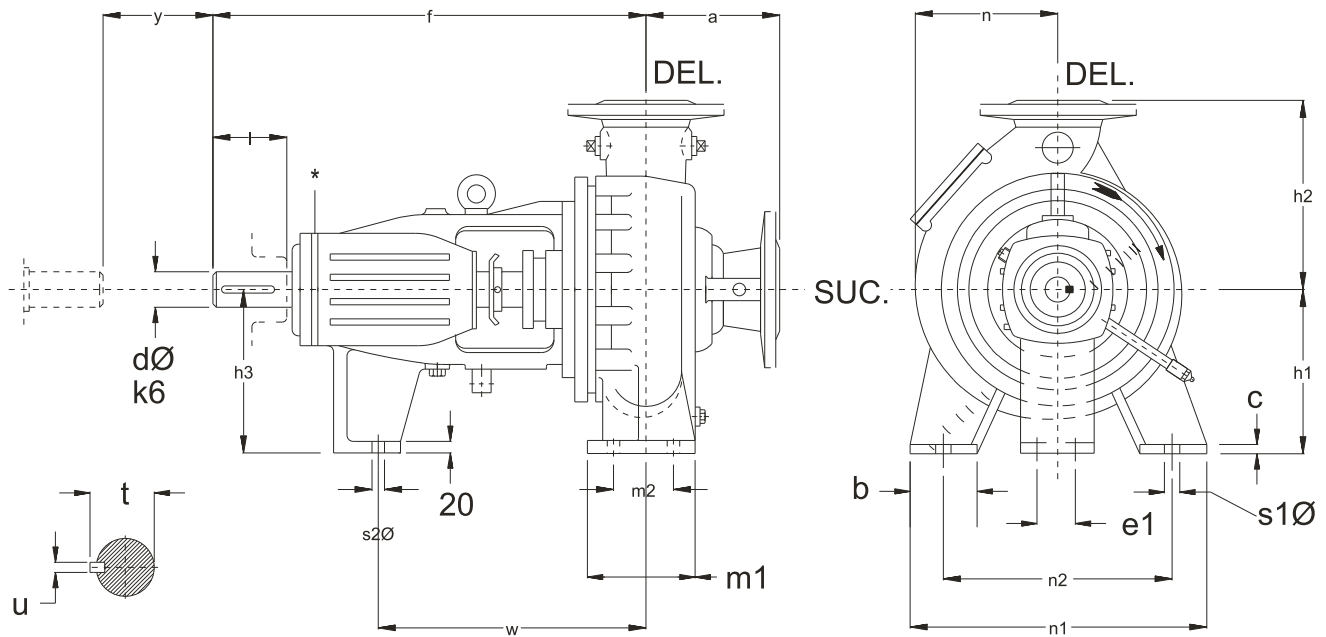

Shaft End

View from Driving End

DIMENSIONS

Pump	Driving Unit	SUC \emptyset	DEL \emptyset	Pump Dimension					Foot Dimensions								Shaft End					Wt. Kg.			
				a	f	h1	h2	n	b	c	m1	m2	n1	n2	s_0^1	s_0^2	e1	w	h3	d \emptyset	l		t	u	y
SHM 50/26	SHM 7	65	50	150	200	250	180	65	135	95	320	250	14				200							100	
SHM 50/26 NB																									570
SHM 65/32		80	65	180	225	280	210	80	160	120	400	315	18				200								120
SHM 65/32 NB																									
SHM 80/26	SHM 9	100	80	200	250	195	180	80	160	120	400	315	18				200							120	
SHM 100/26																									225
SHM 100/32		125	100	180	630	250	315	237	80	18	160	80	400	315	18	15	110	400	225	42	80	45	12	140	165
SHM 80/40																									
SHM 150/26 NB	150	150	200	640	280	355	270	100									410							140	
SHM 100/40	SHM 11	125	100	180	280	355	272	100																200	
SHM 150/26																									270
SHM 150/32		150	150	200	710	400	296	329	20																300
SHM 150/40																									
SHM 200/32		200	200		315	329																			300
SHM 150/50	SHM 13	150	150	225	885	330	450	343	120	22	200	130	560	460	18	15	110	650	330	60	110	63.5	18	180	325
SHM 200/40																									

NOTE:

- 1) All dimensions are in mm
- 2) Dimensions for oil and grease lubricated pumps are common.

SHS PUMP

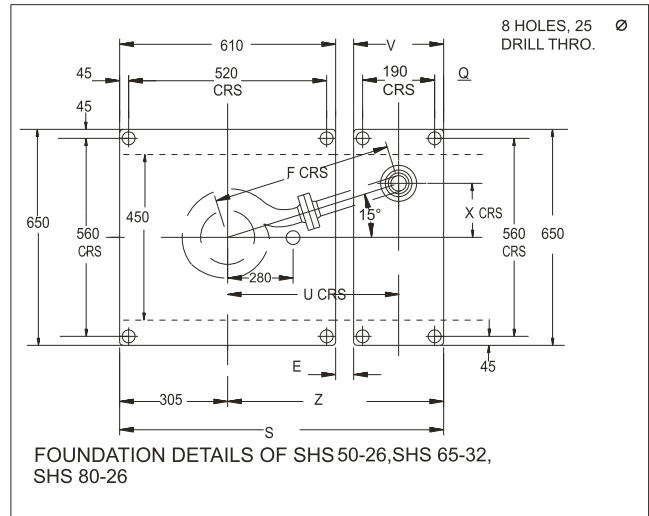
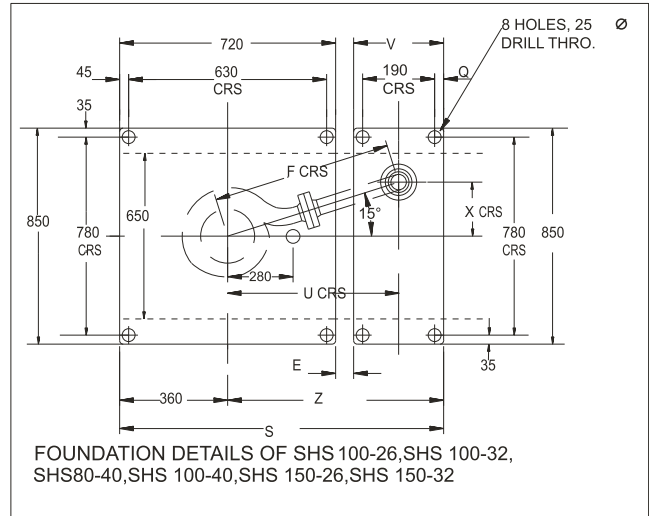
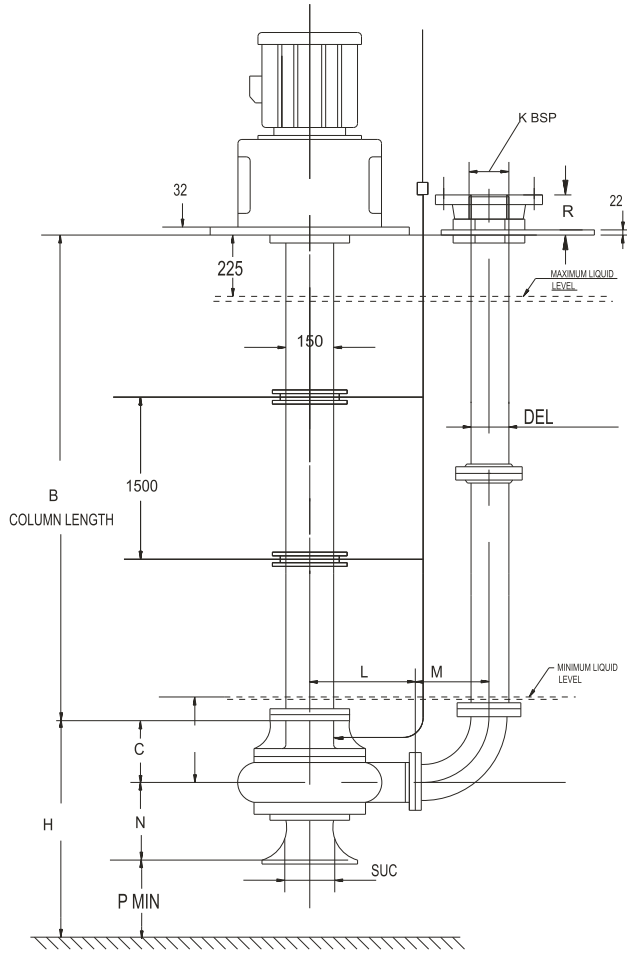

DIMENSIONS

Pump Model	SUC	DEL	H	C	E	F	L	M	N	P	S	W MIN	Z	X	R	K BSP	U	Q	V	Wt. Kg.
SHS 50-26	65	50	535	175	15	492	251	241	202	158	875	550	570	127	103	2"	476	30	250	285
SHS 65-32	80	65	575	175	59	573	281	292	234	166	919	600	614	148	115	2½"	554	30	250	315
SHS 80-26	100	80	610	175	80	581	251	330	233	202	940	600	635	150	115	3"	561	30	250	305
SHS 100-26	125	100	635	190	6	459	281	178	238	207	976	650	616	119	141	4"	444	30	250	460
SHS 100-32	125	100	635	190	30	494	316	178	238	207	1000	650	640	128	141	4"	477	30	250	470
SHS 80-40	100	80	610	190	180	686	356	330	218	202	1150	600	790	178	115	3"	663	30	250	450
SHS 100-40	125	100	650	200	30	534	356	178	238	212	1000	650	640	138	141	4"	516	30	250	505
SHS 150-26	150	150	675	200	79	584	356	228	258	217	1049	800	689	151	104	6"	564	30	250	505
SHS 150-32	150	150	670	200	122	629	401	228	253	217	1092	800	732	163	104	6"	607	30	250	515
SHS 150-40	150	150	675	200	79	584	356	228	258	217	1049	800	689	151	104	6"	564	30	250	530
SHS 200-32	200	200	675	200	79	584	356	228	258	217	1049	800	689	151	104	6"	564	30	250	565

NOTE:

- 1) All dimensions are in mm
- 2) Weights are for pump with 1 m. column length.

CROSS SECTIONAL VIEW SHM PUMP

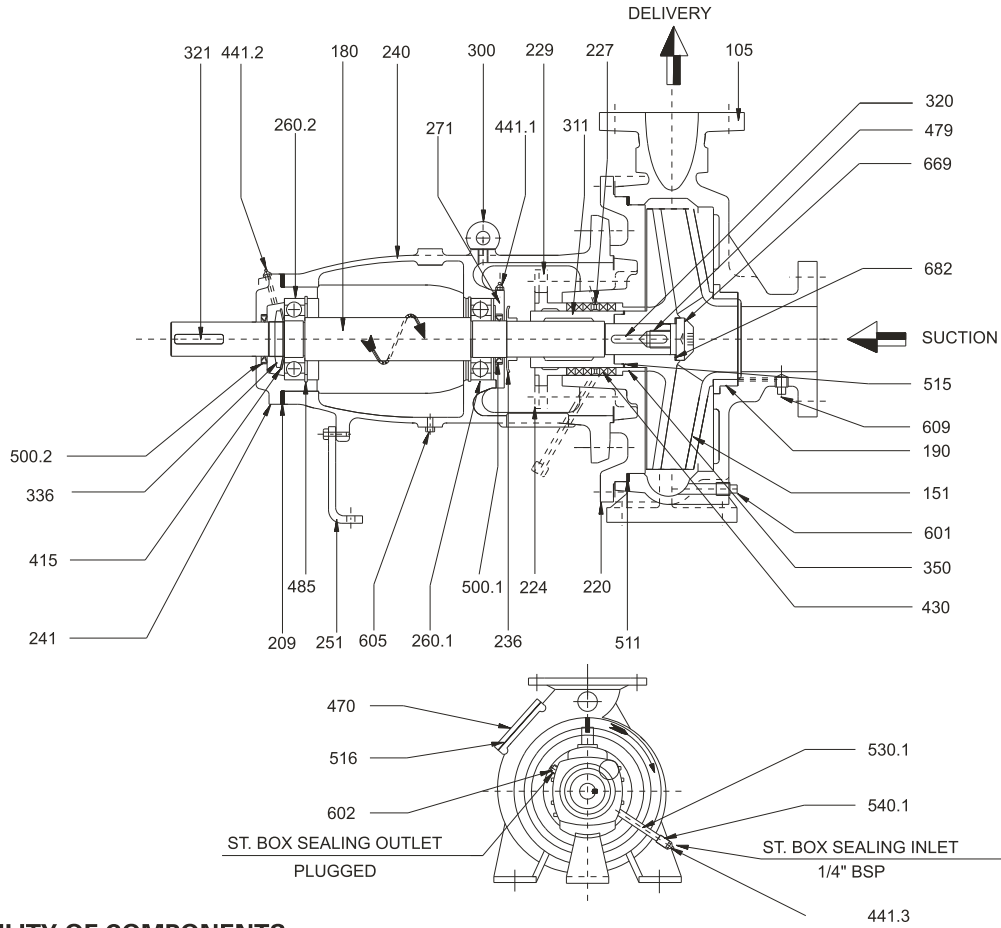

INTERCHANGEABILITY OF COMPONENTS

Part No.	Name of the Part	Total no. of Parts	50/26	50/26B	80/26	65/32	65/32B	100/26	100/32	80/40	150/26B	150/26	150/32	200/32	100/40	150/40	200/40	150/50
			SHM-7					SHM-9					SHM-11				SHM-13	
10500	Pump Casing	13	1	1	2	3	3	4	5	6	7	7	8	9	10	11	12	13
15100	Impeller	16	1	2	3	4	5	6	7	8	9	10	11	12	13	14	15	16
18000	Shaft	4	1	1	1	1	1	2	2	2	2	3	3	3	3	3	4	4
19000	Casing Ring	8	1	1	2	3	3	4	4	2	5	5	5	6	4	5	7	8
22000	Casing Cover	10	1	1	1	2	2	3	4	5	3	6	7	7	8	8	9	10
22700	Lantern Ring	4	1	1	1	1	1	2	2	2	2	3	3	3	3	3	4	4
22900	Gland	4	1	1	1	1	1	2	2	2	2	3	3	3	3	3	4	4
23600	Deflector	4	1	1	1	1	1	2	2	2	2	3	3	3	3	3	4	4
24000	Bearing Housing	4	1	1	1	1	1	2	2	2	2	3	3	3	3	3	4	4
24100	Cartridge	4	1	1	1	1	1	2	2	2	2	3	3	3	3	3	4	4
25100	Support Foot	2	1	1	1	2	2	-	-	-	-	-	-	-	-	-	-	-
26001	Bearing NDE	4	1	1	1	1	1	2	2	2	2	3	3	3	3	3	4	4
26002	Bearing DE	4	1	1	1	1	1	2	2	2	2	3	3	3	3	3	4	4
27100	Bearing Cover	4	1	1	1	1	1	2	2	2	2	3	3	3	3	3	4	4
31100	Shaft Sleeve	4	1	1	1	1	1	2	2	2	2	3	3	3	3	3	4	4
32000	Impeller Key	4	1	1	1	1	1	2	2	2	2	3	3	3	3	3	4	4
32100	Coupling Key	4	1	1	1	1	1	2	2	2	2	3	3	3	3	3	4	4
35000	Stuffing Box Bush	4	1	1	1	1	1	2	2	2	2	3	3	3	3	3	4	4
47000	Inspection Hole Cover	3	1	1	1	1	1	2	2	1	3	3	3	3	2	3	3	3

GENERAL DIMENSIONS / MOUNTING DETAILS

SHS PUMP TYPICAL DRAWING

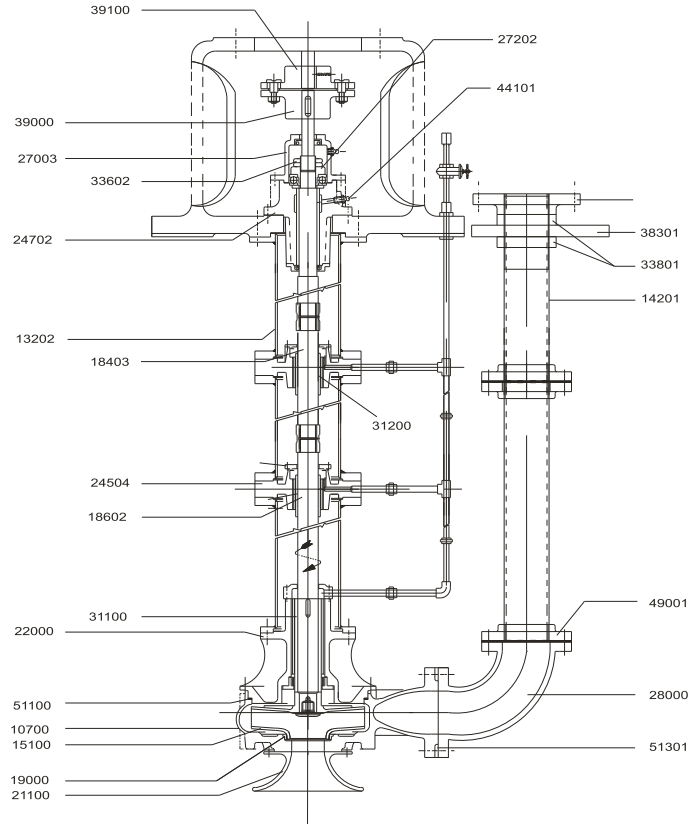

INTERCHANGEABILITY OF COMPONENTS

Part No.	Name of the Part	Total no. of Parts	Pump Model										
			50/26	65/32	80/26	100/26	100/32	80/40	150/26	150/32	200/32	100/40	150/40
107	Pump Casing	11	1	2	3	4	5	6	7	8	9	10	11
132	Top Column Pipe	2	1	1	1	1	1	1	1	1	2	1	2
142	Rising pipes	5	1	2	3	4	4	3	5	5	5	4	5
151	Impeller	11	1	2	3	4	5	6	7	8	9	10	11
184	Intermediate Shaft	1	1	1	1	1	1	1	1	1	1	1	1
185	Head Shaft	2	1	1	1	1	1	1	1	1	2	1	2
186	Pump Shaft	3	1	1	1	2	2	2	3	3	3	3	3
190	Casing Ring	6	1	3	2	4	4	2	5	5	5	4	6
211	Suction Bell Mouth	6	1	3	2	4	4	2	5	5	5	4	6
220	Casing Cover	3	1	2	1	1	2	3	1	2	2	3	3
245	Bearing Spider	1	1	1	1	1	1	1	1	1	1	1	1
247	Thrust Bearing Housing	2	1	1	1	1	1	1	1	1	12	1	2
262	Thrust ball bearing	2	1	1	1	1	1	1	1	1	2	1	2
272	Thrust Bearing Adapter	2	1	1	1	1	1	1	1	1	2	1	2
280	Bend	5	1	2	3	4	4	3	5	5	5	4	5
311	Impeller Shaft Sleeve	3	1	1	1	2	2	2	3	3	3	3	3
338.2	Pipe Nut for Rising Pipe	5	1	2	3	4	4	3	5	5	5	4	5
390	Coupling	To Suit Motor KW and Frame											
391													
395	Screwed Coupling												
490	Companion Flange	5	1	2	3	4	4	3	5	5	5	4	5

DIFFERENT TYPES OF IMPELLER FOR SOLID HANDLING PUMP TYPE 'SHM'

N- TWO VANES ENCLOSED IMPELLER

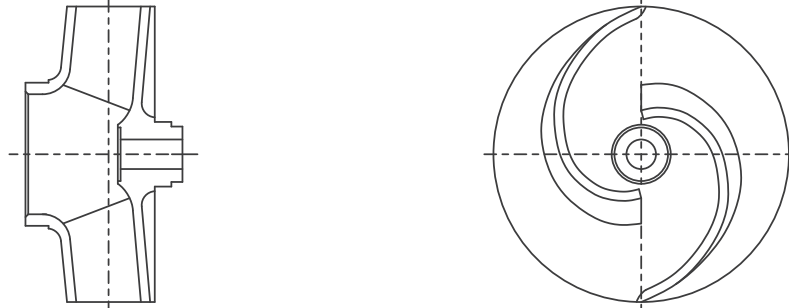

P- SINGLE VANE ENCLOSED IMPELLER

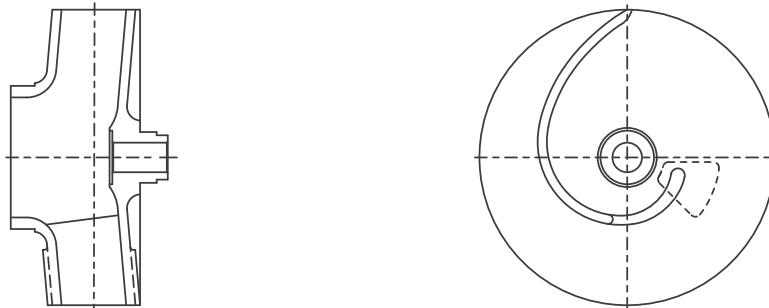

Q/QP - THREE VANES SEMIOPEN IMPELLER

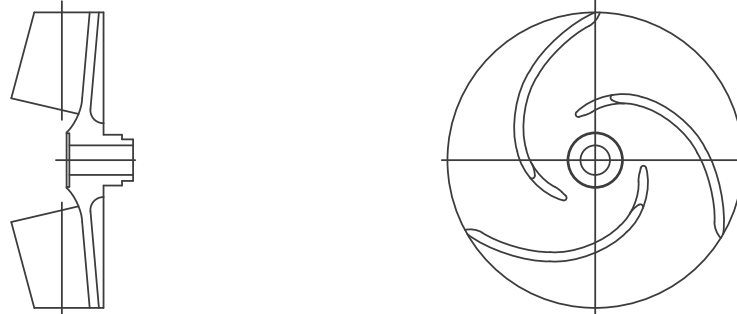

R - EIGHT VANES FREE FLOW IMPELLER

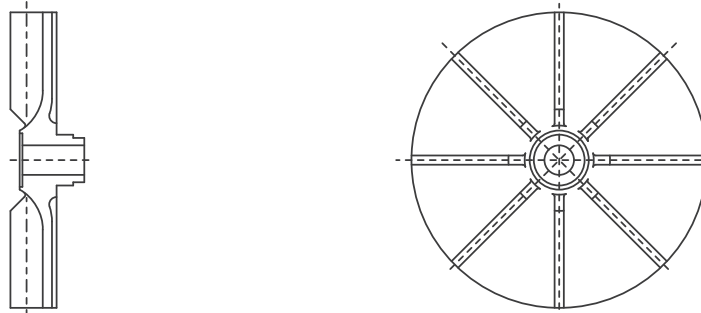

STUFFING BOX COOLING ARRANGEMENT

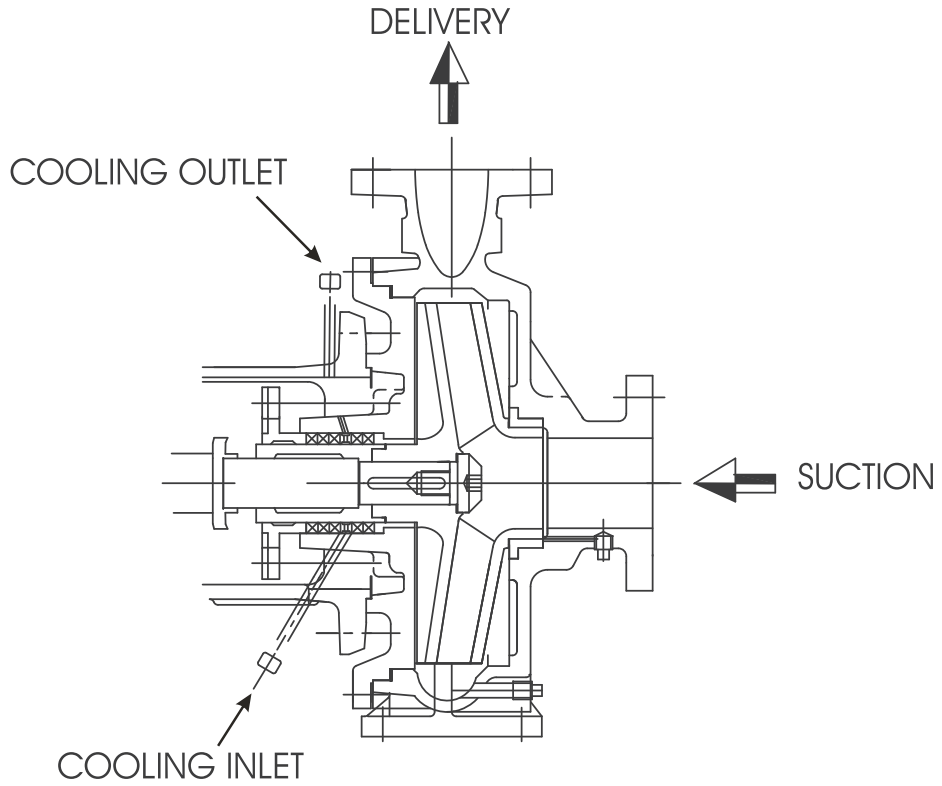

GENERAL DIMENSIONS / MOUNTING DETAILS

ALTERNATIVE AVAILABLE VERTICAL DRY PIT

HORIZONTAL DELIVERY END

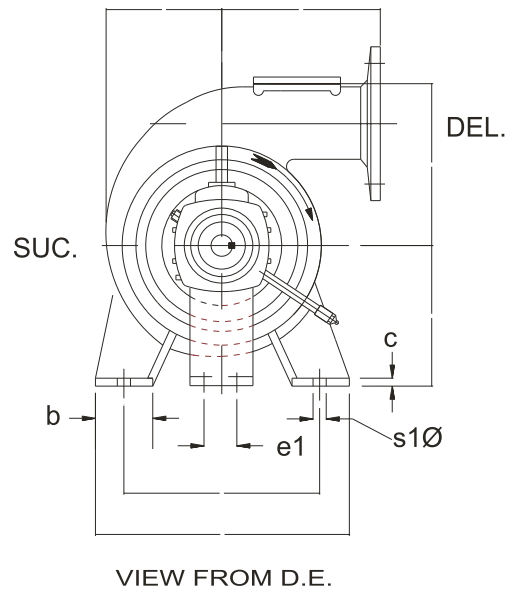
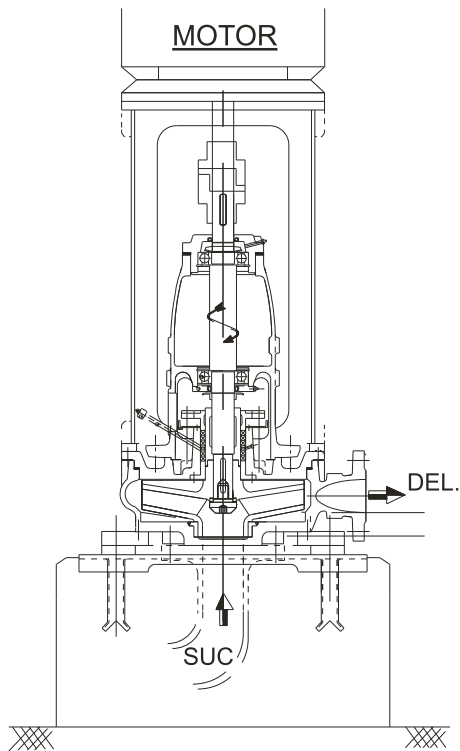

MATERIAL OF CONSTRUCTION

Casing	Cast Iron / Cast Steel / Stainless Steel / Duplex Steel
Casing Cover	Cast Iron / Cast Steel / Stainless Steel
Impeller	Cast Iron / Bronze / Phosphor Bronze / Cast Steel / Stainless Steel / Chrome Steel / Duplex Steel
Wear Ring	Cast Iron / Bronze / Stainless Steel
Shaft	Carbon Steel / Stainless Steel / Duplex Steel
Shaft Sleeve	Stainless Steel / Bronze / Chrome Steel
Lantern Ring	Cast Iron / Bronze / Stainless Steel
Gland	Cast Iron / Bronze

MATERIAL STANDARDS - GENERAL INFORMATION

Material Type	Indian Standard (IS)	American standard (ASTM)	DIN
Cast Iron			
Cast Iron	IS 210 Gr. FG 260	ASTM A48 Class 40	(0.6025)DIN 1691 GG25
Spheroidal Graphite Cast Iron			
SG Iron (Ductile Iron)	IS 1865 Gr 400/15	A536, 60-40-18	(0.7040)DIN1693 GGG40
SG Iron (Ductile Iron)	IS 1865 Gr 500/7	A536, 65-45-12	(0.7050)DIN1693 GGG50
Carbon steel			
Carbon steel (Wrought)	IS 1570 (part II) Gr. 40C8	ASTM A107 Gr. 1040	(1.1186)C40E/CK40
Carbon steel (Wrought)	IS 1570 (part II) Gr. 20C8	ASTM A107 Gr. 1020	(1.0402)C22
MS Steel	MS IS 2062 - Fe 410 W A	ASTM-A283 GR.D	DIN 1700 GR ST4-2 FABRICATED STEEL44
Cast Steel Grades			
Cast steel		ASTMA 216 Gr. WCB	1.0619(GS-C25)
Cast Stainless Steel			
Stainless Steel CF8M	IS 3444 Gr. 4	ASTMA 351 Gr. CF8M	1.4408(GX5CrNiMo19-11-2)
Stainless Steel CF8M	IS 3444 Gr. 4	ASTMA 743 Gr. CF8M	1.4408(GX5CrNiMo19-11-2)
Stainless Steel CF3M	IS 3444 Gr. 16	ASTMA 351 Gr. CF3M	1.4409(GX2CrNiMo19-11-2)
Stainless Steel CF3M	IS 3444 Gr. 16	ASTMA 743 Gr. CF3M	1.4409(GX2CrNiMo19-11-2)
Stainless Steel CF8	IS 3444 Gr. 1	ASTMA 351 Gr. CF8	1.4301(X5CrNi18-10)
Stainless Steel CF3	IS 3444 Gr. 15	ASTMA 351 Gr. CF3	1.4306(X2CrNi19 11)
Cast Chromium StainlessSteel			
Stainless Steel CA15	IS 3444 Gr. 10	ASTMA 217 Gr. CA15	1.4106&1.448(DIN17445 GX12Cr14)
Stainless Steel CA15	IS 3444 Gr. 10	ASTMA 743 Gr. CA15	1.4106&1.448(DIN17445 GX12Cr14)
Stainless Steel CA6NM	IS 3444 Gr. 24	ASTMA 487 Gr. CA6NM	1.4313&1.4317(GX5CrNiMo13-4)
Stainless Steel CA6NM	IS 3444 Gr. 24	ASTMA 743 Gr. CA6NM	1.4313&1.4317(GX5CrNiMo13-4)
Chromium StainlessSteel Round Bar Material			
Stainless steel 410	IS 1570 (part V) Gr. X12Cr12	ASTMA 276 type 410	1.4006(X10Cr13)
Stainless steel 420	IS 1570 (part V) Gr. X20Cr13	ASTMA 276 type 420	1.4021(X20Cr13)
Stainless steel 431	IS 1570 (part V) Gr. X15Cr16Ni2	ASTMA 276 type 431	1.4057(X20CrNi17)
Stainless steel 316	IS 1570 (part V) Gr. X04Cr17Ni12Mo2	ASTMA 276 type 316	1.4401(X5CrNiMo17122)
Stainless steel 316L	IS 1570 (part V) Gr. X02Cr17Ni12Mo2	ASTMA 276 type316L	1.4404(X2CrNiMo1810)
Cast Duplex Steel			
Duplex Steel 1A		ASTMA 890 Gr. CD4MCu	25Cr-5Ni-Mo-Cu
Duplex Steel 2A		ASTMA 890 Gr. CE8MN	24Cr-10Ni-Mo-N
Duplex Steel 3A		ASTMA 890 Gr. CD6MN	25Cr-5Ni-Mo-N
Super Duplex steel 4A		ASTMA 890 Gr. CD3MN	25Cr-7Ni-Mo-N
Super Duplex steel 5A		ASTMA 890 Gr. CE3MN	24Cr-10Ni-Mo-N
Non Ferious Materials			
Bronze	IS 318 Gr. LTB2 (CuSn5Zn5Pb5C)	ASTMB 584 - C90500	DIN 1705 Rg 5
Phosphor Bronze	IS 28 Gr. 1 (CuSn11PC)		
Zinc Free Bornze	IS 28 Gr. 1 (CuSn10C)		

FAMILY CURVES

SHM/SHS/SHV/SHVT Pumps at 1450 rpm - 50 Hz.

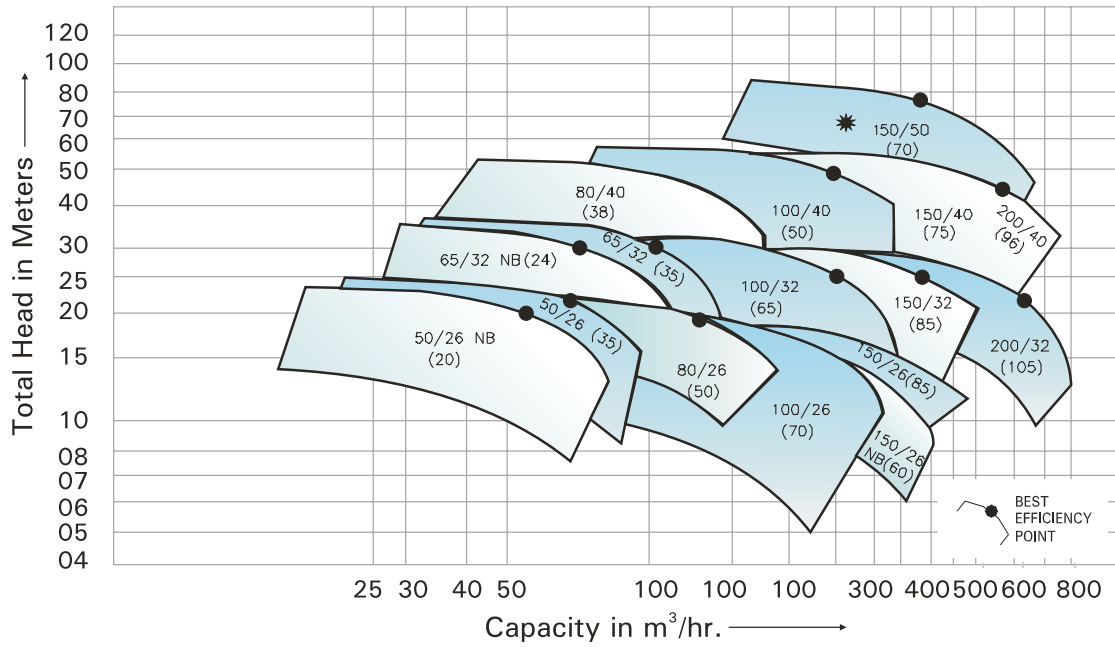

Note : Figures in bracket indicate maximum permissible solid size.

* Not applicable for SHS Pump

SHM/SHS/SHV/SHVT Pumps at 980 rpm - 50 Hz.

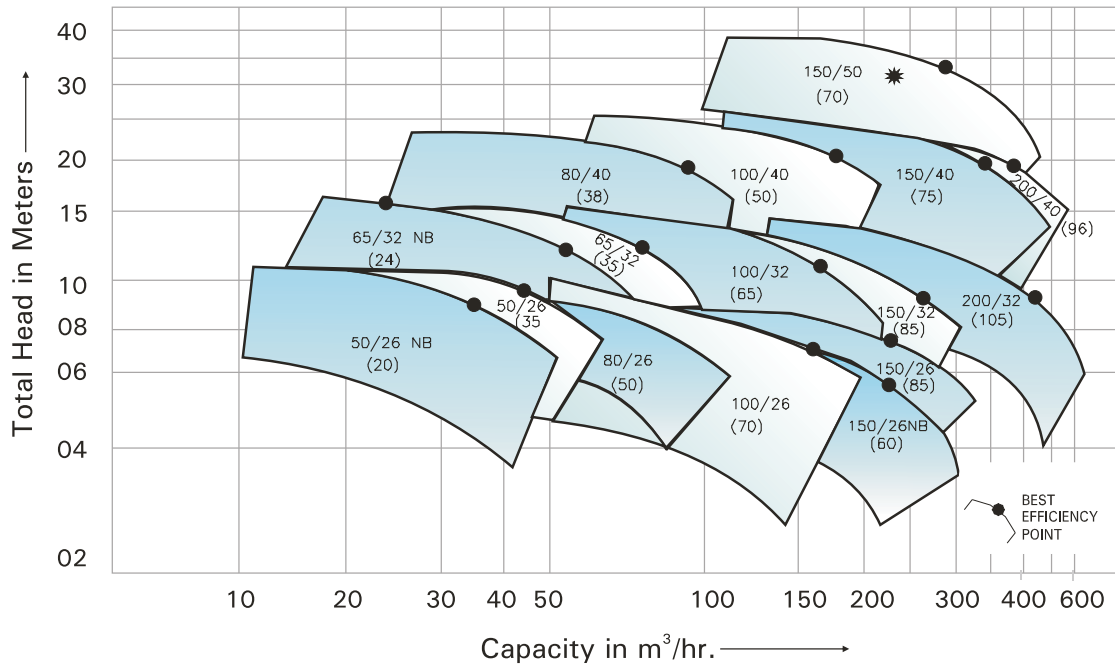

Note : Figures in bracket indicate maximum permissible solid size.

* Not applicable for SHS Pump

FAMILY CURVES

SHM/SHS/SHV/SHVT Pumps at 1150 rpm - 60 Hz.

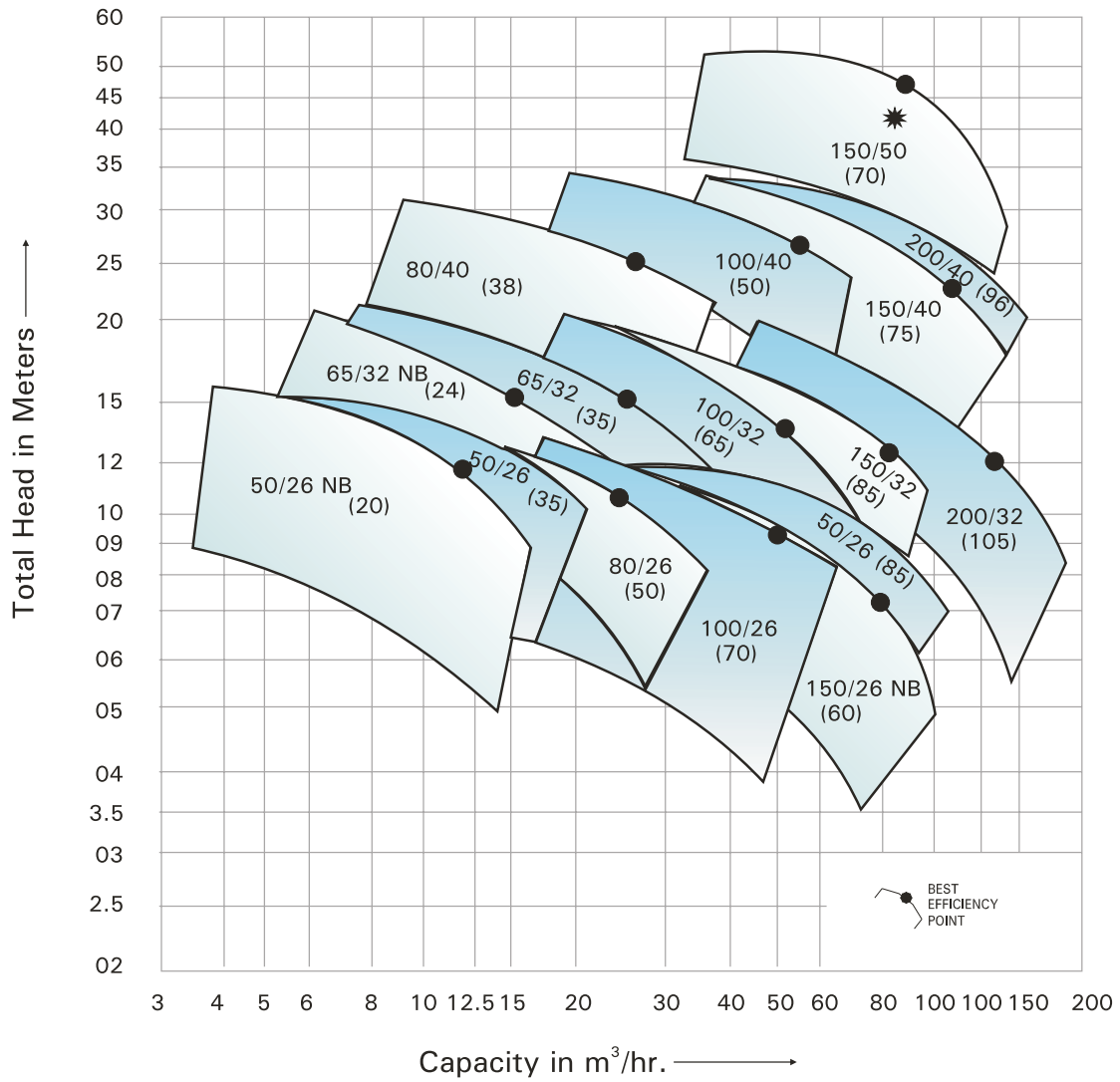

Note : Figures in bracket indicate maximum permissible solid size.

* Not applicable for SHS Pump

OUR GLOBAL PRESENCE



As we are constantly endeavouring to improve the performance of our products/ equipment, we reserve the right to make alterations from time to time and as such our products/ equipment may differ from that detailed in this publication. For latest information you may get in touch with our Regional Sales Offices.



Enriching Lives

KIRLOSKAR BROTHERS LIMITED

CORPORATE OFFICE :

"YAMUNA" Survey No. 98 (3/7), Baner,
Pune - 411045, INDIA
Tel.: +91 20 27214444 Fax: +91 20 27211117
email: kblin@kbl.co.in website: www.kbl.co.in

WORKS :

Kirloskarvadi 416308 Dist. Sangli
Maharashtra, INDIA
Tel.: +91 2346 222301 to 222305
Fax: +91 2346 222311

